

Optimization of Loudspeakers

A.J. Svobodnik, T. Nizzoli, F.L. Redl
Mvoid Group, Karlsruhe, Germany

Introduction

Loudspeakers, specifically electrodynamic transducers with enclosures (also called cabinets), are used almost everywhere in our daily life. Transportation of acoustic information is vital for humans since the very beginning of the human evolution. Hence, reproduction of acoustics has a long tradition in engineering sciences. Many of the fundamental inventions are more than 100 years old – the 100th anniversary of the electrodynamic transducer is unclear, but the research paper in 1925 by Chester W. Rice and Edward W. Kellogg at General Electric[1] might be called the birth of the electrodynamic loudspeaker.

Almost 100 years of engineering evolution of loudspeakers also means lots of new ideas, inventions, and improvements. Today's performance parameters of electrodynamic transducers look like a different device than compared to the first prototypes back in 20s of the last century. It is said that we are now in quite a flat technology curve where huge efforts need to be invested for relatively small improvements. As a conclusion, we believe that applying mathematical optimization models to improve the performance of electrodynamic transducers might be a chance for another era of revolutionary rather than evolutionary progress in loudspeaker design.

This paper will demonstrate the application of optimization procedures to various types of loudspeakers, i.e. sealed and ported ones, to optimize specific performance targets.

Devices Under Test

We have used some of our benchmark examples for which detailed measurements are available, and hence a validated starting model can be re-used for optimization.

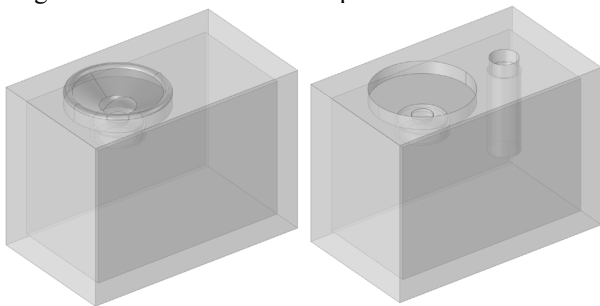

Figure 1. A sealed cabinet with woofer (left) and a ported cabinet with subwoofer (right)

A typical 6.5" inch subwoofer and a woofer are used as transducers for a loudspeaker. These devices show the following Thiele-Small parameters:

Name	Expression	Value	Description
Vrms	2[V]	2 V	Driving rms voltage
Bl	6.1[N/A]	6.1 Wb/m	Force factor
Re	3.4[ohm]	3.4 Ω	Resistance
Le	1.08[mH]	0.00108 H	Inductance
L2	1.58[mH]	0.00158 H	L2 LR2 Model
R2	7.81[ohm]	7.81 Ω	R2 LR2 Model
Sd	0.01583[m²m]	0.01583 m²	Membrane area
Kms	1670[N/m]	1670 N/m	Stiffness of suspensions
Mmd	23[g]	0.023 kg	Moving mass without air...
Qms	6.84	6.84	Mechanical Q
V0	Vrms*sqrt(2)	2.8284 V	Driving peak voltage
pol	-1	-1	Polarity , if in the Polarity...
rho0	1.22[kg/m³]	1.22 kg/m³	
c0	345[m/s]	345 m/s	
Vrms_max	8[V]	8 V	Maximum RMS voltage

Figure 2. Woofer (top) and subwoofer (bottom)

The geometry of these cabinets is based on a SOLIDWORKS® model, and is connected to the simulation model (including also the optimization) by means of LiveLink™ for SOLIDWORKS®. All relevant geometry parameters can therefore be accessed by the optimization algorithm:

Sync CAD name	COMSOL name	COMSOL value
<input checked="" type="checkbox"/> inner_width	LI_inner_width	155 mm
<input checked="" type="checkbox"/> port_diameter	LI_port_diameter	40 mm
<input checked="" type="checkbox"/> wall_thickness	LI_wall_thickness	19 mm
<input checked="" type="checkbox"/> port_position_from_transducer	LI_port_position_from_transducer	133 mm
<input checked="" type="checkbox"/> depth0	LI_depth0	80 mm
<input checked="" type="checkbox"/> height0	LI_height0	90 mm
<input checked="" type="checkbox"/> height1	LI_height1	200 mm
<input checked="" type="checkbox"/> port_length	LI_port_length	120 mm
<input checked="" type="checkbox"/> inner_depth	LI_inner_depth	200 mm
Read-only parameters		
<input checked="" type="checkbox"/> inner_height	LI_inner_height	290
<input checked="" type="checkbox"/> port_volume	LI_port_volume	1.507965
<input checked="" type="checkbox"/> acoustic_mass	LI_acoustic_mass	116.98
<input checked="" type="checkbox"/> speaker_distance	LI_speaker_distance	90 mm

Figure 3. Controllable CAD parameters

Typical results in terms of SPL on-axis responses for the initial configurations, i.e. without optimization, is given in the following graphics:

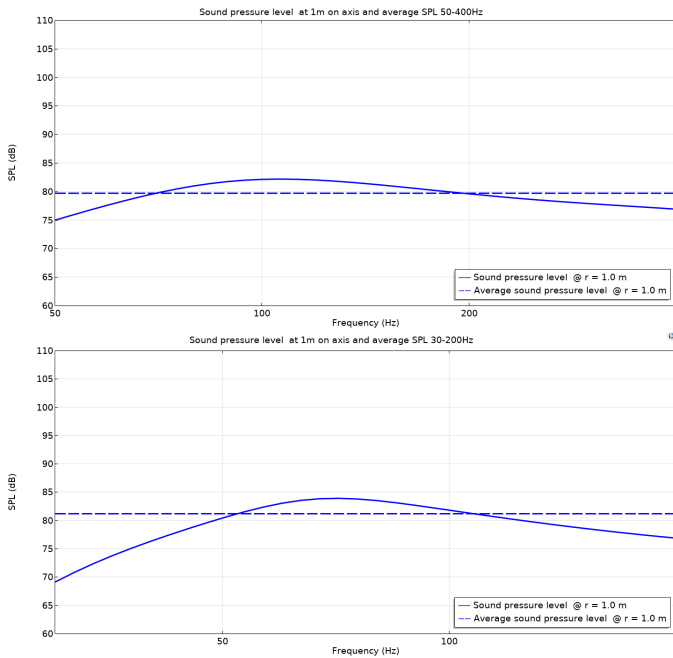

Figure 4. Frequency response of initial configurations for woofer (top, 50 Hz < f < 400 Hz) and subwoofer (bottom, 30 Hz < f < 200 Hz)

Further details of these examples can be found in [2].

Mathematical Optimization

There are many examples for mathematical optimizations. Typical applications can be found in mechanics, economics and finance, diverse engineering disciplines like electrical or civil engineering, and operations research, among many others. Common to all these is that they either a) minimize or b) maximize a function:

$$f : A \rightarrow \mathbb{R}$$

$$\mathbf{x}_0 \in A$$

$$a) f(\mathbf{x}_0) \leq f(\mathbf{x}) \text{ for all } \mathbf{x} \in A$$

or

$$b) f(\mathbf{x}_0) \geq f(\mathbf{x}) \text{ for all } \mathbf{x} \in A$$

The function f is typically called an objective or cost function. A solution that fulfills a) or b) is called an optimal solution. One important challenge here is to distinct between local and global optima. As the names imply, the local optimum might not be the best minimization or maximization to a given engineering problem, e.g. the optimization of some specific loudspeaker performance parameters. This can result in solutions that would not guarantee significant product improvements. More details are beyond the scope of this paper, but it should be noted that it is mostly the cause of failure in optimization.

It should also be noted that eventually the optimization of loudspeakers requires multi-dimensional (also called multi-objective) optimizations. I.e. that there is more than one objective function to fulfill. This will be investigated in future publications with some initial results given in [3].

Also, the role of constraints in optimization problems is of crucial importance. A constraint optimization is minimizing or maximizing an objective function with constraint variables, which are either of type hard or soft. Hard constraints are required to be satisfied, while soft constraints are introduced into the objective function by means of a penalty function.

The requirement of constraints makes an optimization problem significantly harder to solve, but usually leads to better engineering designs in terms of feasibility and robustness.

Some algorithms of the COMSOL® Optimization Module [4] have been used to optimize performance parameters of the loudspeaker examples given in one of the previous sections. Excessive use of constraints is shown in the optimization examples to underline the importance of these.

Constraint Optimizations Applied to Loudspeakers

First, we will show the optimization of a typical performance parameter of a woofer with a sealed cabinet. As most of the loudspeaker cabinets are non-axisymmetric in geometry, the loading from the sound pressure inside the cabinet on the membrane is non-axisymmetric as well, and can lead to the so-called “rocking” behavior, as seen here:

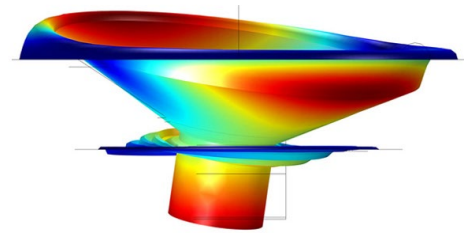
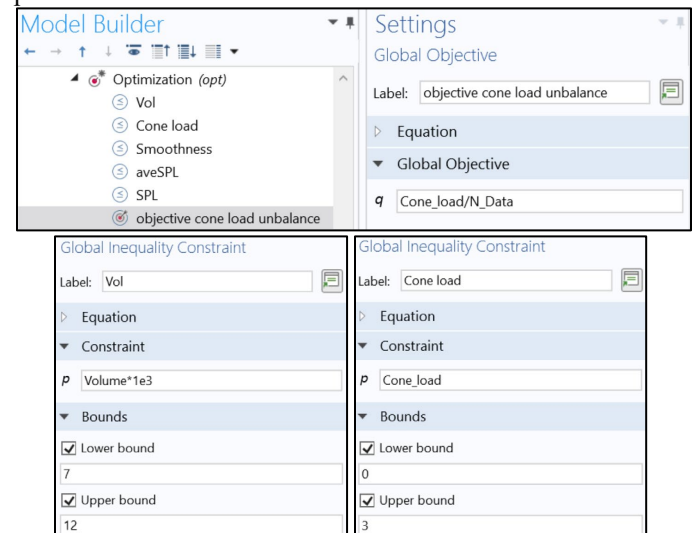

Figure 5. Typical loudspeaker “rocking”

Rocking is a very critical effect and can lead to extremely unpleasant rub & buzz effects and is highly audible as well. Hence it is a typical optimization target to minimize load variations on the membrane. Subsequently, the optimization problem looks as follows:



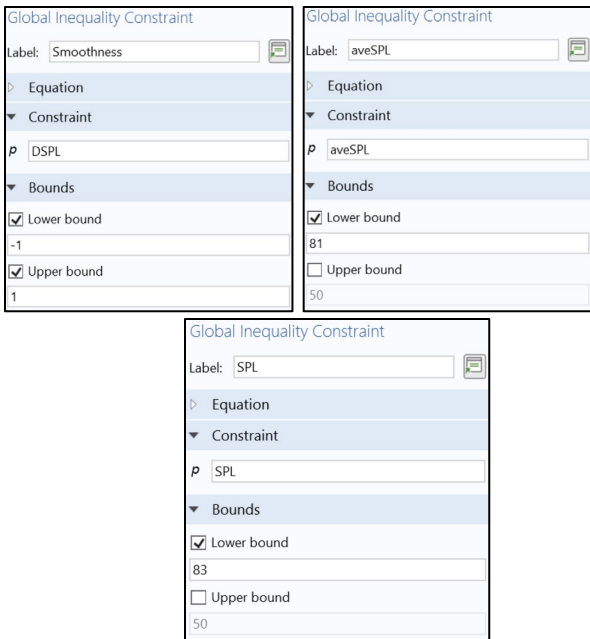

Figure 6. Definition of the objective function and its constraints

The constraints were selected as such, that the principal acoustic performance parameters of the loudspeaker are maintained.

A comparison between the initial configuration and the optimized one, with a reduction in load unbalance of approximately 50 % can be seen in the following figure:

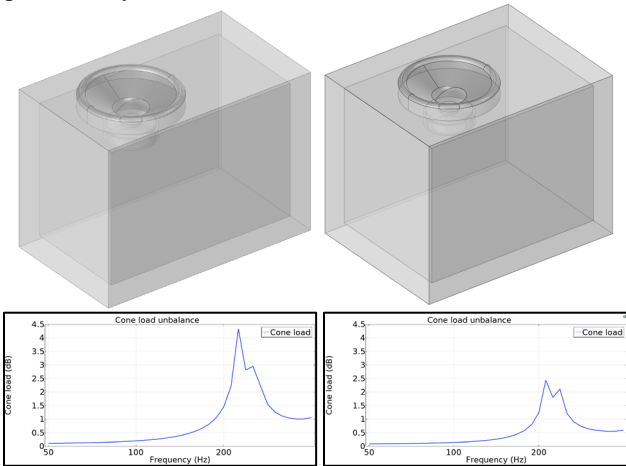

Figure 7 Optimized cabinet geometry (right) with a reduction of 50 % in load unbalance

It should be noted here that this optimization does not increase product costs at all.

The next example gives a more complex situation for a ported enclosure with a subwoofer optimizing the tuning frequency to a given target. The tuning frequency is the resonance frequency of the air in the port, and a typical performance parameter specified by system engineers in the audio industry. This acoustic resonance is significantly boosting the acoustic output of the loudspeaker around this frequency and hence improves the sensitivity.

The optimization problem looks as follows:

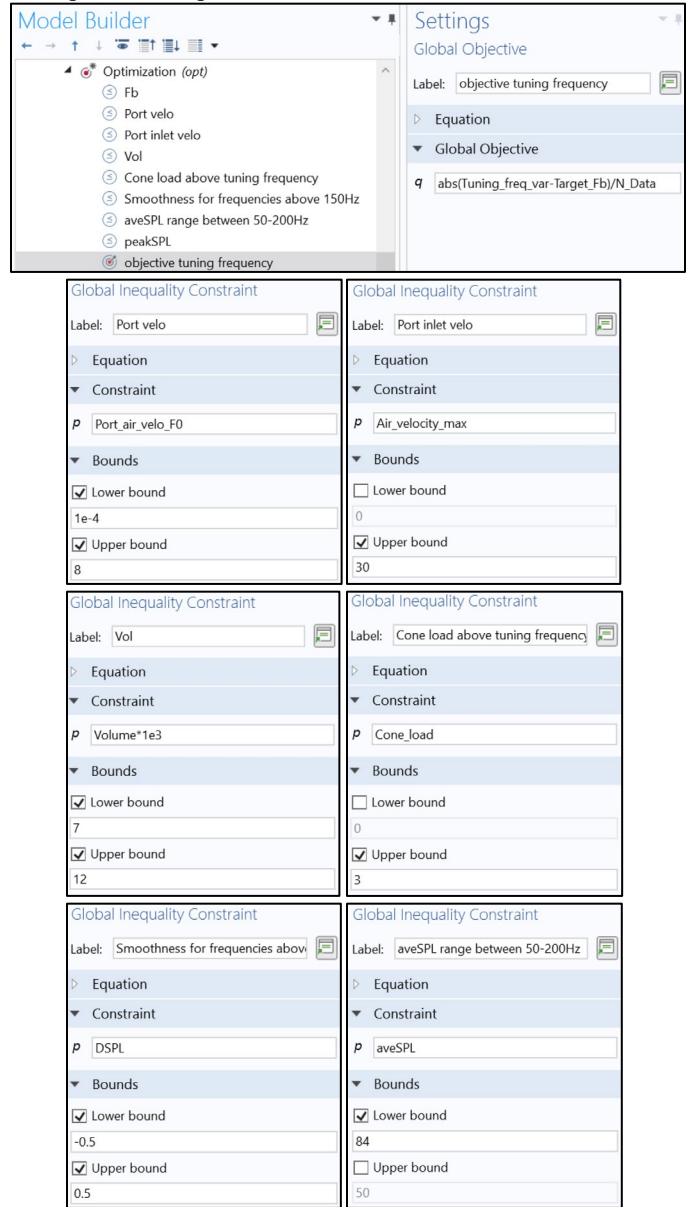

Figure 8. Definition of the objective function and its constraints

Again, the constraints were selected as such, that the principal acoustic performance parameters of the loudspeaker are maintained.

A comparison between the initial configuration and the optimized one, with a shift of the tuning frequency from 45 Hz to 55 Hz can be seen in the following figure:

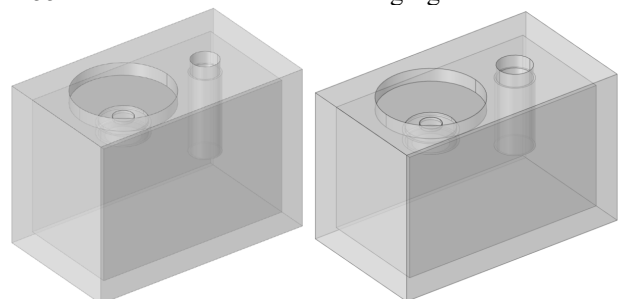

Figure 9 Optimized cabinet geometry (right) with a shift of the tuning frequency from 45 Hz to 55 Hz

Once again, it must be noted here that this optimization does not increase product costs at all.

Conclusions

The application of mathematical optimization with constraints to some typical engineering tasks in loudspeaker engineering could be demonstrated. By using COMSOL® Multiphysics 5.5 and the Mvoid® Simulation Process Technology 2.3 it could be shown that specific performance parameters can be significantly improved, while the general performance of the system is still given. Additionally, these improvements can be done without additional product costs.

References

- [1] Rice, Chester W. and Edward W. Kellogg, "Notes on the Development of a New Type of Hornless Loudspeaker," Transactions of the American Institute of Electrical Engineers 44, 1925, p. 461-475
- [2] Mvoid Professional Audio GmbH, "The Mvoid® Simulation Process Technology - Professional Audio Version - Version 2.3", 2020
- [3] T. Nizzoli, T. Gmeiner, A.J. Svobodnik, A. Saratov, "Mehrdimensionale Optimierung von Lautsprechern", 2020 NAFEMS DACH Regionalkonferenz
- [4] COMSOL, "COMSOL Multiphysics 5.5 – Optimization Module", 2020